

HEAVY DUTY



WLP 500 Trailer

Caratteristiche

- Adatto per lavori in condizioni estreme
- Macchina su carrello con ruote di ampia sezione per facile spostamento su terreni accidentati
- Alta efficienza
- Pompa acqua multistadio in acciaio inox
- Portata acqua variabile
- Angolo di rotazione liberamente impostabile
- Gestione tempi pausa lavoro
- Filtro acqua in acciaio inox
- Ugelli in acciaio inox
- Pronto per gestione con software centralizzato

Features

- Suitable for working in extreme conditions
- Machine on cart with large wheels section for easy movement on rough terrain
- High efficiency
- Water pump multistage stainless steel
- Variable water flow rate
- Angle of rotation can be set freely
- Time break labor management
- Water filter stainless steel
- Stainless steel nozzles
- Ready for centralized management software

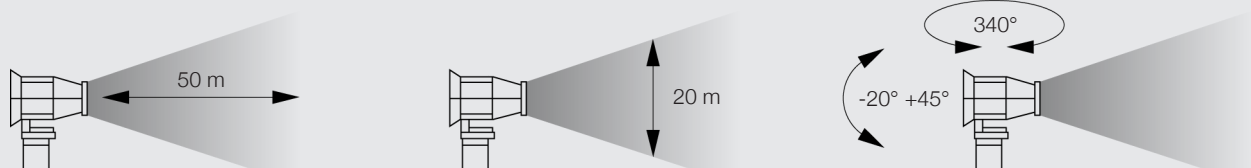

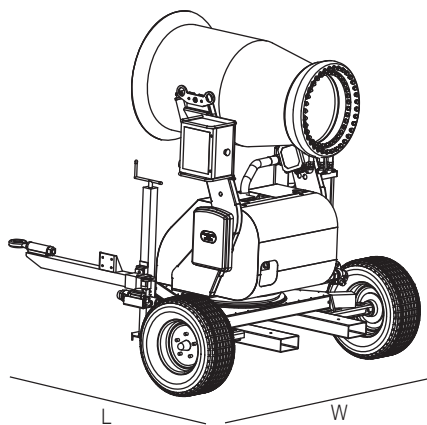

Dati Tecnici

Technical Data

WLP 500 Trailer

Potenza installata	Installed power	kW	8,7
Potenza ventilatore	Fan power	kW	5,5
Potenza pompa acqua	Water pump power	kW	2,2
Grado di protezione	Protection rating	IP	55
Alimentazione	Power supply	A / Volts / Hz	su richiesta / on request
Alzo	Pitching	°	- 20° +45°
Distanza max del getto	Max throw distance	m	40 - 50
Rumorosità	Noise level	Lwa	< 93
Peso a secco	Dry weight	Kg	527

Dimensioni
Dimensions

L x H x W (mm)

1880 x 1960 x 1600

Consumo acqua con ugelli da 10 - 15 GPH
Water consumption with 10 - 15 GPH nozzles

BAR	12
L./min.	30
L./max.	75

HD
HEAVY DUTY