

# LIPPMANN

Specifications

## 200c-r Track-Mounted Cone Crusher

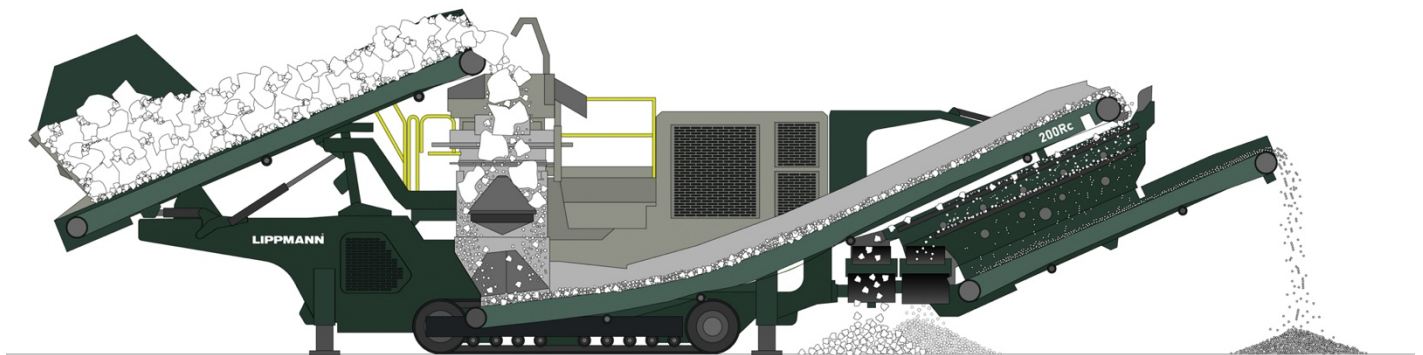

### DESCRIPTION

Heavy duty track mounted crusher with following features:

- MC200 cone
- 360Hp Volvo D11 T4 Final engine or 350Hp CAT C9 Tier 3 engine
- Tracked
- Integrated hopper with folding rear door
- I-beam plate fabricated chassis construction
- Large gap between crusher discharge and main conveyor feedboot
- Open chassis design for ease of maintenance
- Fast setup time

### DIMENSIONS AND WEIGHTS

Length - transport all models	18.52m (60' - 9")
Width - transport all models	3.49m (11' - 5")
Height - transport truck	3.4m (11' - 2")
Weight - track	48,430 Kgs (106,770 lbs.)

### CAPACITIES

Diesel tank capacity	595L (157 US gal)
Hydraulic tank capacity	650L (172 US gal)

## FEEDER

Feeder opening width	800mm (36")
Feeder drum crs.	6000mm (19' 8.2")
Drive	Hydraulic
Feeder belt width	1050mm (48")
Motor	Danfoss OMSS 125
Gearbox	Bonfig 809 W2 24.2:1
Flow rate	87.4 Lpm (23.1 US gpm)
Adjustable speed	Yes
Maximum speed	29 rpm

## CRUSHING CHAMBER

Feed opening	914mm (38")
Crusher input speed	750 - 950 rpm
Crusher drive	Direct drive
Min. opening	See chart below
Max. opening	See chart below
Cone weight	10,400kg (22,928 lbs.)
Closed side setting adjustment	Hydraulic
Level sensor	Ultrasonic
Throw	77mm at discharge with new liners
Power required	200 hp

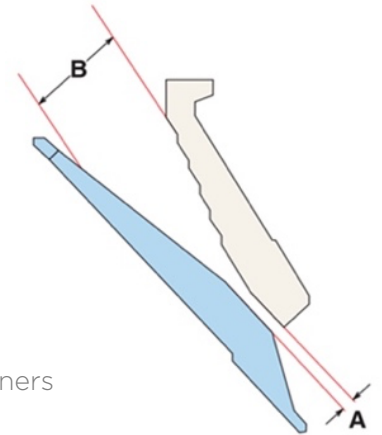

### CRUSHER CAVITY SELECTION

		STANDARD	
CRUSHER SIZE	CAVITY	MINIMUM SETTING "A" 1	FEED OPENING "B" 2
MC200	Fine	13mm (0.5")	95mm (3.74")
	Medium	17mm (0.67")	125mm (4.92")
	Coarse	19mm (0.75")	185mm (7.28")
MC300	Fine	13mm (0.5")	107mm (4.21")
	Medium	17mm (0.67")	150mm (5.91")
	Coarse	19mm (0.75")	211mm (8.31")
MC400	Fine	20mm (0.79")	198mm (7.8")
	Medium	25mm (0.98")	252mm (9.92")
	Coarse	30mm (1.18")	299mm (11.77")

## HOPPER

Length	3780mm (12' - 4.9")
Width	2200mm (7' - 2")
Volume	5m <sup>3</sup> (6.5yd <sup>3</sup> ) leveled off, 6.2m <sup>3</sup> (8.1 yd <sup>3</sup> ) heaped
Material	6mm sides + 10mm Hardox liners

## MAIN CONVEYOR

Stockpile	4236mm (13' - 10.8")
Belt width	1200mm (48")
Belt spec	Plain 500/3 8+2
Drive drum dia.	350mm (13.7")
Tail drum dia.	270mm (10.6")
Motor	OMV800
Flow rate	89.6 Lpm (23.7 US gpm)
Maximum speed	112 rpm
Angle adjustable	Yes
Quick release	Yes

## POWERUNIT AND HYDRAULICS

Engine	Volvo D11 T4 final engine
Engine power	268 Kw (360HP)
Engine speed	1570 - 1900 rpm
Cone drive clutch	PTtech HPTO14TF1
Flywheel pump 1 (tracks / feeder)	Kawasaki K3VL80
Flywheel pump 2 (tracks / main conveyor)	Kawasaki K3VL80
LH PTO pump 3 (auxiliary / lube / pilot)	Turolla 29/29/10
Front PTO pump 4 (recirc screen / conveyors)	Turolla 45/36
Total system flow (max)	335 Lpm (88.5 US gpm)
Hydraulic tank capacity	60 L (211 US gals)
Hydraulic tank ratio	1.7:1
Hydraulic oil cooler	Yes

## RECIRC SYSTEM - SCREENBOX

Dimensions - top deck	3660mm x 1525mm (12' x 5')
Dimensions - bottom deck	3050mm x 1525mm (10' x 5')
Bearing type	NSK/RHP 22219
Screens - top deck	5' x 4' side tension - 2 off & 5' x 2' side tension - 2 off
Screens - bottom deck	5' x 4' side tension - 2 off & 5' x 2' side tension - 1 off
Tensioning - top and bottom decks	Quick release pin and wedge
Screen angle	25°
Screen motor	DBH MCC2208 (59cc/rev)
Drive system	Direct drive with HRC150 coupling
Hydraulic flowrate	Yes - pressure compensated FCV
Screen stroke adjustable	8 - 10mm
Screen shaft speed	950 rpm
Screen 'g' force	5.05

## **RECIRC SYSTEM – RETURN CONVEYOR**

Belt width	650mm (26")
Belt spec	Chevron - 500/3 5+1.5 C15
Drive drum dia.	290mm (11.5")
Tail drum dia. (spoked)	270mm (10.6")
Motor	OMT500
Flow rate	68.4 Lpm (18 US gpm)
Adjustable speed	Yes
Maximum speed	135 rpm
Quick release	Yes
Radial to side for stockpiling	Yes

## **RECIRC SYSTEM – TRANSFER CONVEYOR OVERSIZE**

Belt width	500mm (26")
Belt spec	Plain 600/3 4+2
Drive drum dia.	178mm (7")
Tail drum dia.	187mm (7.36") - spoked
Motor	OMH500
Flow rate	68.4 Lpm (18 US gpm)
Adjustable speed	Yes
Maximum speed	135 rpm

## **RECIRC SYSTEM – FINES CONVEYOR**

Stockpile height	2863mm (9' - 4.7")
Belt width	1200mm (48")
Belt spec	Plain 500/3 8+2
Drive drum dia.	285mm (11.2")
Tail drum dia.	270mm (10.6") - spoked
Motor	OMV630
Flow rate	Up to 72.6 Lpm (19.2 US gpm)
Maximum speed	Up to 115 rpm

## **RECIRC SYSTEM – TRANSFER CONVEYOR MID PRODUCT (2 DECK ONLY)**

Stockpile height	1872mm (6' - 1.6")
Belt width	650mm (26")
Belt spec	Plain 400/3 4+2
Drive drum dia.	188mm (7.4")
Tail drum dia.	188mm (7.4")
Motor	OMT500
Flow rate	Up to 68.8 Lpm (18.2 US gpm)
Adjustable speed	Yes
Maximum speed	Up to 138 rpm

## ELECTRICS

Emergency stops	4 off, 2 feeder, 2 powerunit
Chassis cabling	Armored cable
Start siren	Yes - 10 sec delay
Control panel	Tedd Engineering / IFM
Engine shutdowns	Low oil pressure High water temp Air filter blockage (selectable) Fuel contamination Low hydraulic tank level Low lube oil flow Low lube oil pressure High lube oil temperature High hydraulic oil temperature
Radio control tracks and feeder	Standard
Pendant track control	Yes - plugged in control cabinet

## TRACKS

Width	400mm (15.7")
Length	3800mm (12' - 5.5") crs
Height	817mm (33.5")
Gearbox	Bonfiglioli 711
Ratio	144:1
Motor	Rexroth A2FE90
Speed max	1.50 Kph (0.93 mph)
Flow rate	152 Lpm (40.2 US gpm)
Multiple speeds	Three speed system selectable at control panel with smooth start / stop

## OPTIONS

- Hopper extensions
- Water pump and dust suppression system
- Various cone liner options
- Work lights
- Belt scale
- Refueling pump - standard

## SAFETY FEATURES

- External belt alignment points
- External grease points
- Engine safety shutdown systems
- Full safety guarding for nip points

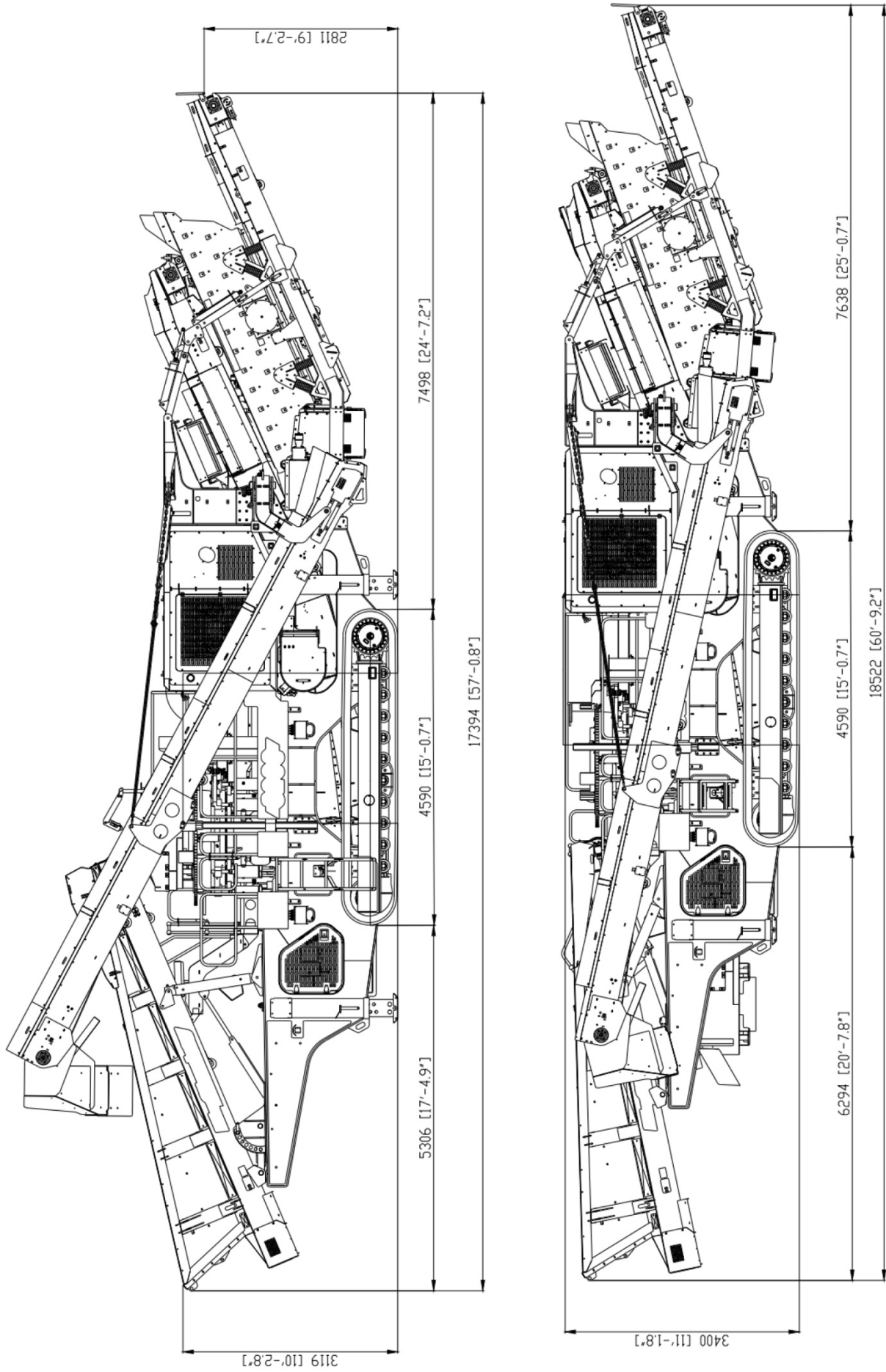

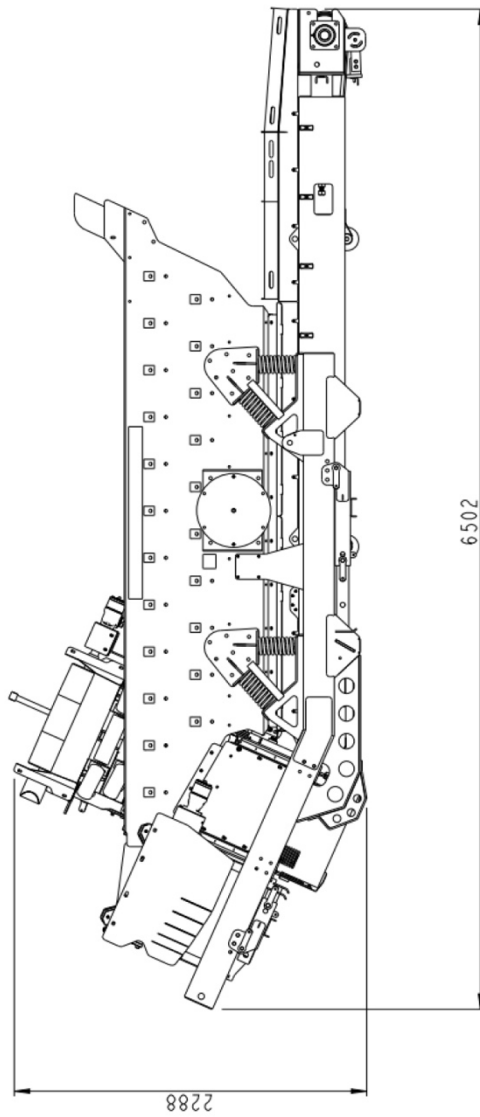
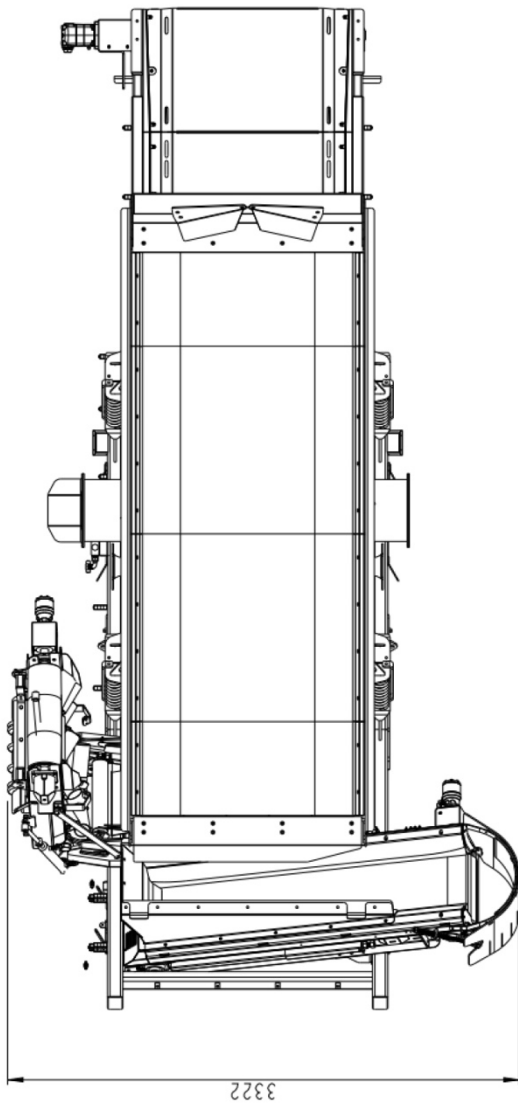
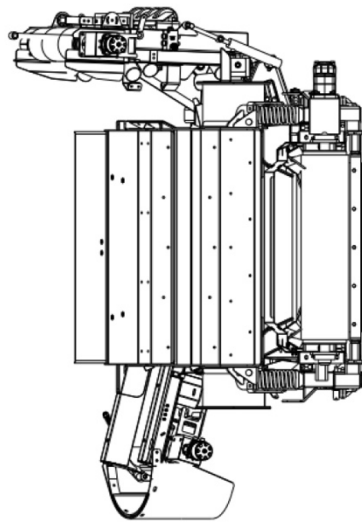

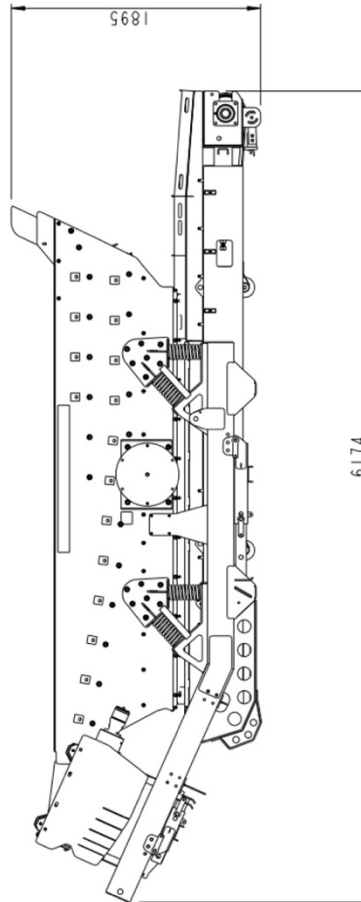
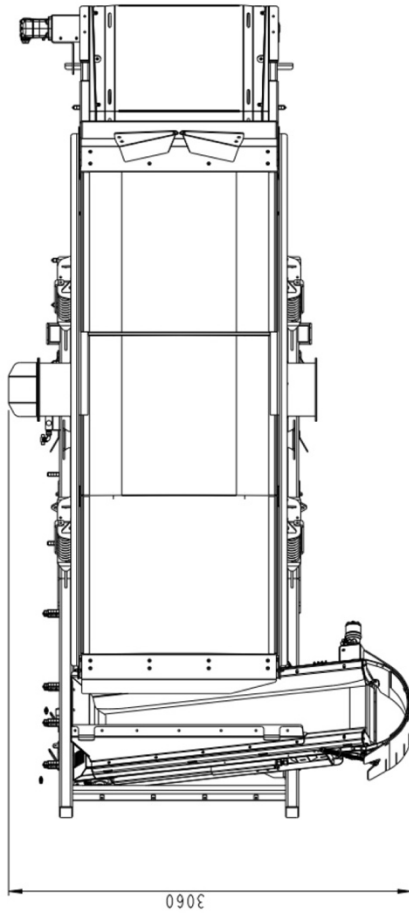
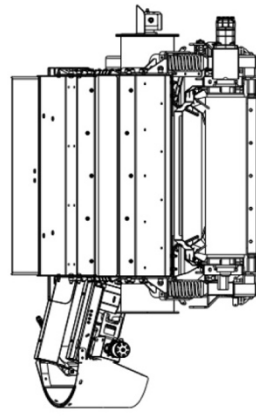

# LIPPMANN

Metso McCloskey USA, LLC  
 dba: Lippmann  
 3271 East Van Norman Avenue  
 Cudahy, WI 53110-0586 USA  
[www.lippmann-milwaukee.com](http://www.lippmann-milwaukee.com)

Lippmann European Office  
 47 Moor Road  
 Coalisland, Co. Tyrone BT714QB Northern Ireland  
 (+44) 28-8774-0926  
[www.lippmannglobal.com](http://www.lippmannglobal.com)

All specifications are current as of this pricing, but are subject to change.